

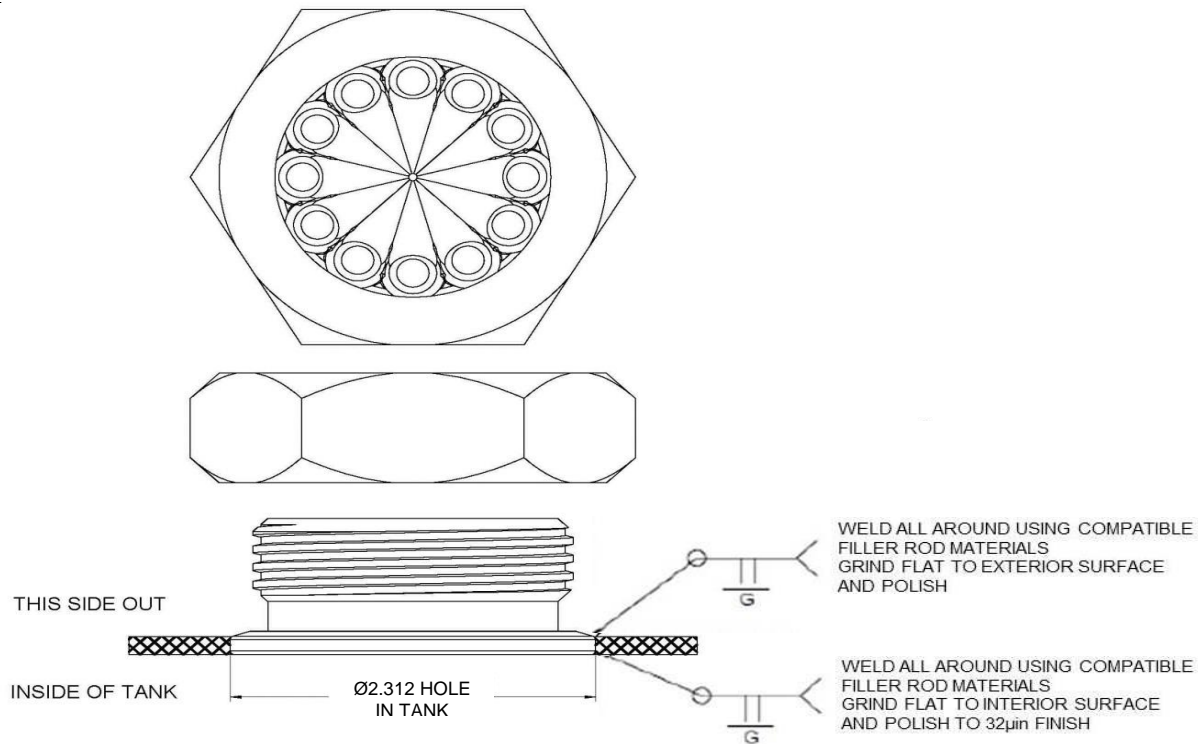

Quality Management, Inc. (QMI)  
www.qmisystems.com  
651-501-2337

Welding instructions for the following part numbers:

☐ PN 212214



3-A Sanitary Standards authorized: Sanitary Fittings, Number 63-03; Authorization Number: 838